

Quick Start Guide

MS-890 Industrial Automation Scanner



P/N 83-210052 Rev A

Step 1 — Check Hardware

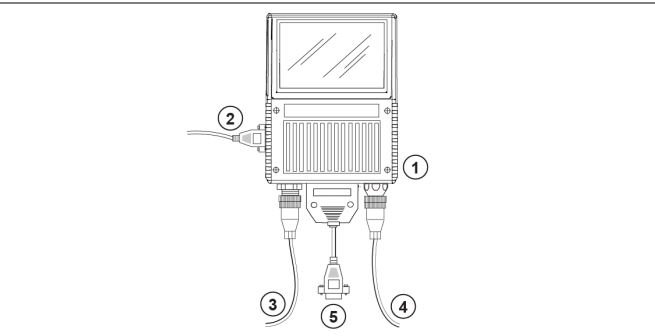

Hardware Required

Caution: Be sure that all cables are connected **BEFORE** applying power to the system. Always power down **BEFORE** disconnecting any cables.

Item	Description	Part Number
1	MS-890 Scanner	FIS-0890-0001, -0002
2	Configuration Cable	61-000010-02
3	Power Supply	97-100004-15
4	Object Detector (optional)	99-000004-01
5	Comm./Serial Cable	61-000034-02

Note: Standalone configuration shown above. See the *MS-890 Configuration Sheet* for other configuration options.

Step 2 — Connect the System

Connecting the MS-890 Standalone

- Attach the configuration cable (2) to the 9-pin (preferred) or 25-pin (on bottom of unit) connector to configure, test, and default the scanner.
- Attach the power supply cable (3) to the 3-pin power connector on the bottom of the scanner.

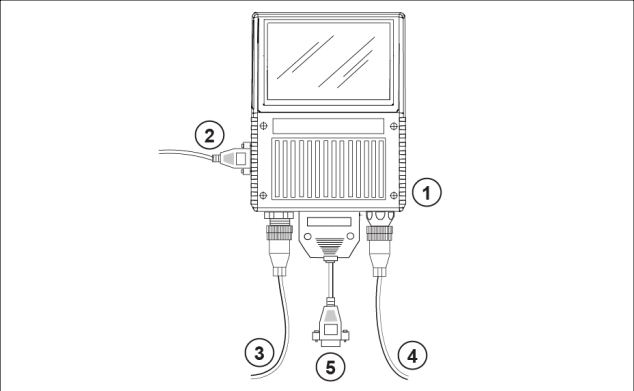

Hardware Configuration

Caution: Be sure that all cables are connected **BEFORE** applying power to the system. Always power down **BEFORE** disconnecting any cables.

Step 3 — Install ESP

Easy Setup Program (ESP) is Microscan's proprietary setup and testing application. The purpose of **ESP** is to provide a quick and easy way to set up and configure Microscan products.

When the MS-890 is connected to a host computer (Windows XP or 2000), **ESP** can be used to set up communication with a host, configure various firmware settings, and control verification processes.

Important: To migrate MS-880 settings to MS-890 settings, refer to Chapter 2, "Using ESP", in the *MS-890 Industrial Automation Scanner User's Manual*.

If installing from a Microscan Tools CD:

1. Insert the Microscan Tools CD in your computer's CD drive.
2. Choose **ESP Software** from the main menu.
3. Select the **Current Version of ESP** and follow the file download prompts.

If downloading from the web:

1. Go to <http://www.microscan.com/downloadcenter>
2. Create a new "myMicroscan" member account or, if you are already a member, enter your user name and password.
3. Click the **Download Software** link and extract the latest version of **ESP** to a directory of your choice. *Note where your ESP.exe file is stored on your hard drive.*
4. At the end of the installation process, the following icon will appear on your desktop:



5. Click the **ESP** icon to start the program.

System Requirements for ESP

- 166 MHz Pentium processor (recommended)
- Windows XP or 2000 operating system
- Internet Explorer 5.0 or higher
- 64 MB minimum RAM
- 40 MB minimum disk space

Step 4 — Select Model

When you start **ESP**, this menu will appear:



- Select the MS-890 from the menu and click **OK**. If you do not want to make this selection every time you start **ESP**, uncheck "Show this dialog at startup".
- Click **Yes** when the following dialog appears:

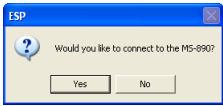

Note: If you need to select another model later, click the **Switch Model** button near the top of the screen.

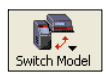

Step 5 — Autoconnect

- Select the appropriate port and click **Start** when the following dialog appears.

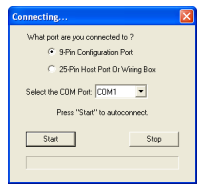

Note: If your communications port is not the default **COM1**, use the dropdown menu to change your port.

- Once you have chosen the correct port, click **Start** to connect.

When you are connected, you will see the green connection indicator in the status bar at the bottom right of your screen:



- If the connection attempt fails, click the **Autoconnect** button, select a different communications port, and try again.

Note: If your RS-232 host settings cannot be changed to match the scanner's settings, select **Connect...** from the **Connect** menu in the menu toolbar, and then click the **Force Connect** box when you see the dialog shown at right.

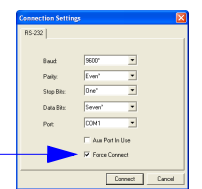

Step 6 — Receive Settings

To copy the scanner's memory settings into **ESP**, right click in the configuration window and select **Receive Reader Settings** from the dropdown menu.

Receive Reader Settings

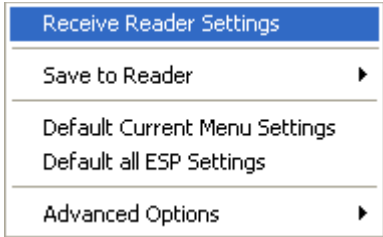

When you select **Receive Reader Settings**, the settings from the scanner's memory are sent to **ESP**.

Step 7 — Position Scanner and Symbol

Set up a symbol at the distance that will be used in your application.

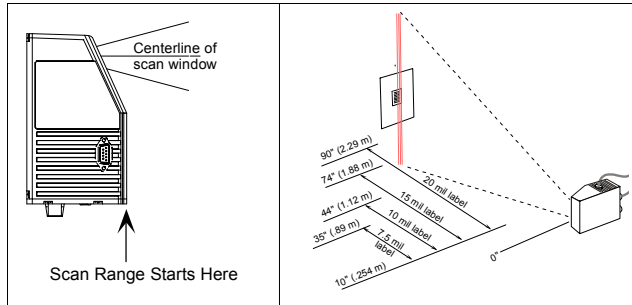

Note: Code 39 is the default symbology enabled. If you are uncertain as to the symbology type in your application, enable all symbologies as follows:

- Click the **Autodiscriminate** button in **EZ Mode**. All symbologies will be enabled.

Important: If using Interleaved 2 of 5 symbols in your application, verify that the number of characters in the symbols being scanned matches the symbol length enabled for the 1-2 of 5 symbology (default is 10 and 6).

Step 8 — Calibrate

- Click the **Calibration** button in **EZ Mode** or in the **Calibration** view.

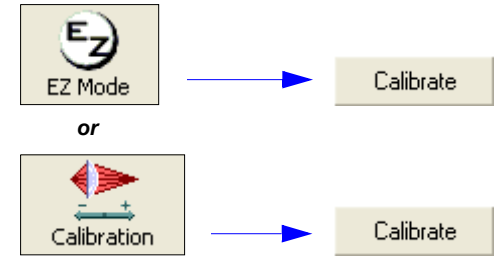

- You can also calibrate from the **Terminal** by sending **<@CAL>**.
- Allow some time for the scanner to cycle through the focus, gain, and tracking settings. Do not move or disturb the scanner or test symbol while calibration is in progress.
- When calibration is complete, the settings that provided the highest read rate will be selected. You will see one of the following messages: "Calibration Passed," "Calibration Failed," or "Original Settings Were Optimal."

Note: To silence the beeper, interrupt scanning by removing or blocking the test symbol, or send a **<K702,0>** command to disable the beeper.

If calibration fails, try the following:

- Check the read range for your particular symbol density.
- Examine symbol quality and try a different sample symbol.
- Slightly skew or tilt the symbol or scanner to minimize specular reflection.
- Verify that the correct symbology is enabled.

Step 9 — Test Read Rate

Important: To receive symbol data through the 9-pin configuration port, you must enable the port with the following command: **<K146,,1>**.

- Position the symbol in front of an operational MS-890 scanner.
- Click the **Utilities** button.
- Click the **Start** button in the **Read Rate** view.

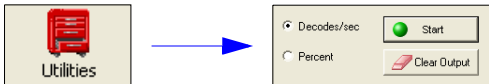

If calibration has passed, the scanner sends data to the host computer and emits a beep (if the beeper is enabled) for each good read.

Move your symbol toward the scanner and away from the scanner until the decode rates drop off in each direction. This will give you a sense of the depth of field (inner and outer ranges) for your symbol's density and range.

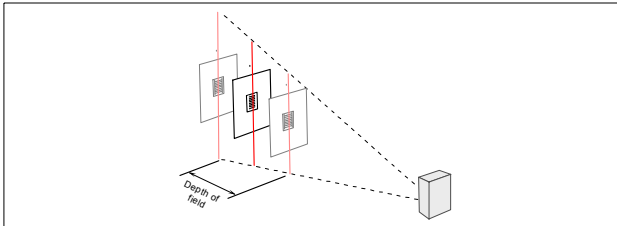

Note: If the scanner is in the default **Continuous Read** mode and not in read rate or calibration routine, it will read and beep repeatedly as long as a readable symbol remains in the read range and the read cycle configuration has not changed.

- To end the read rate test, right click **Read Rate** and select the **Stop** button.

Step 10 — Configure the Scanner Using ESP

To make setup changes to the MS-890, click the **App Mode** button.



The following modes are accessible by clicking the buttons in the first row of **App Mode** icons:



- Test and Calibrate** the scanner in **EZ Mode**.
- Establish communications between **ESP** and the scanner by clicking the **Autoconnect** button.
- Send or receive commands by clicking the **Send/Recv** button.
- Test and calibrate the laser and change **Configuration Database** settings in **Calibration**.
- Make changes to laser behavior and raster settings in **Raster/Laser**.
- Access the **Terminal**, where you can view symbol data and enter serial commands.
- Review status settings or make changes to operational commands in **Utilities**.
- Format data output characteristics in **Output Format**.

Click the **Configuration** button to display the second row of **ESP** icons.



From here you can make changes in the tree controls that can be accessed by clicking the buttons on the second row of icons in the **ESP** window.



For further details, see **ESP Help** for the MS-890.

Step 11 — Make Menu Changes and Save in ESP

To make changes to a configuration setting:

- Left click** on the **+** to expand the desired tree.
- Double click** on the desired parameter and click once in the selection box to view options.
- Place your cursor in the selection box, scroll down to the setting you want to change, and **click** once on the setting.

Parameters	ESP Values
[-] Communications	
+ R5232/422 Host Port	
+ R5232 Auxilliary Port	
+ Aux/Config System Data	
+ Preamble	Disabled*
+ Postamble	Disabled*
Response Timeout	Enabled
LRC Status	Disabled
Intercharacter Delay	0

- Left click** again on the open screen to complete your selection.
- Right click** on the open screen and select **Save to Reader** to implement the command in the scanner.

Saving Options

- Send, No Save.** Changes will be lost when power is re-applied to the scanner.
- Send and Save.** This activates all changes in current memory and saves to the scanner for power-on.

